



## Digital Color Doppler Ultrasound System

Model: CBit 4

Instruction Manual

57-01372-00

Mar. 1<sup>st</sup>, 2022

V1.1

CHISON Medical Technologies Co., Ltd.

We reserve the right to make changes to this manual without prior notice.

## Notice d'information

### Documentation utilisateur complète disponible sur demande

Vous consultez actuellement une version synthétique de la documentation relative à ce dispositif médical.

Seule une version allégée du manuel d'utilisation est mise à disposition sur notre site internet. Le manuel utilisateur complet peut être obtenu gratuitement sur simple demande.

Pour recevoir la version intégrale du manuel, nous vous invitons à compléter le formulaire de contact disponible sur notre site internet en précisant la référence du produit concerné.

Notre équipe vous transmettra la documentation complète dans les meilleurs délais, sous format électronique.

Pour toute question complémentaire, notre service client reste à votre disposition.

Important : Avant toute utilisation du dispositif, assurez-vous d'avoir pris connaissance des informations et consignes adaptées à votre usage.

### La direction

## Regulatory Requirement



This product conforms to the essential requirements of the Medical Device Directive 93/42/EEC. Accessories without the CE mark are not guaranteed to meet the Essential Requirements of the Medical Device Directive.

This manual is a reference for the CBit 4. Please verify that you are using the latest revision of this document. If you need the latest revision, contact your distributor.

### **NOTE:**

#### ***Important***

1. No part of this manual may be reduced, modified, copied or reprinted, in whole or in part, without written permission from CHISON.
2. The contents of this manual are subject to change without prior notice and without our legal obligation.
3. Before operating the system, please read and understand this manual. After reading, keep this manual in an easily accessible place. If you have any question or doubt, please contact CHISON's authorized service engineer.
4. CHISON's Warranty only cover material and parts costs for repair, but do not cover any labor cost or onsite service cost at end user's side.

## **NOTE:**

### Important information

1. It is the customer's responsibility to maintain and manage the system after delivery.
2. The warranty does not cover the following items, even during the warranty period:
  - a) Damage or loss due to misuse or abuse with system and probes, for example, drop the probe, the liquid or the metal part fall into the system.
  - b) Damage or loss caused by Acts of God such as fires, earthquakes, floods, lightning, etc.
  - c) Damage or loss caused by failure to meet the specified conditions for this system, such as inadequate power supply, improper installation or environmental conditions.
  - d) Damage or loss caused by non-approved transportation by CHISON.
  - e) Damage or loss due to use the system outside the region where the system was originally sold.
  - f) Damage or loss involving the system purchased from a source other than CHISON or its authorized agents.
3. Do not make changes or modifications to the software or hardware of this system and probes.
4. During operating the system, if user has any doubt, difficulty or any unclear, please contact CHISON's authorized service engineer immediately. Please describe the situation clearly to solve the question in time. Before solving the question, please don't operate the system.
5. This system shall not be used by persons other than fully qualified and certified medical personnel.
6. It is prohibited to use the device for fetal sex examination, except for necessary medical needs. The device can only be sold to qualified medical institutions or doctors. The users shall fully understand and master the devices before operating. The users shall have got the qualification, and shall comply with the local laws and regulations, the local religion and customs, etc.
7. The System modified or repaired by people other than CHISON's qualified service engineers, CHISON shall not be liable for the system.

8. The purpose of this system is to provide physicians with data for clinical diagnosis. It is the physician's responsibility for diagnostic procedures. CHISON shall not be liable for the results of diagnostic procedures
9. This manual contains warnings regarding foreseeable potential dangers, but user shall always be alert to dangers other than those indicated as well. CHISON shall not be liable for damage or loss that results from negligence or from ignoring the precautions and operating instructions described in this operation manual.
10. Due to negligence not following operation manual, CHISON shall not be liable for the results.
11. Each time before and after ultrasound examination, please check the probe surface, probe cable and sheath whether they are abnormal, such as cracking, peeling and deformation. Also check whether the lens is strongly fixed. Abnormal probes may cause electric shock and injure the patient. Once any abnormal, user must stop using and contact CHISON's authorized service engineer.
12. If the probe is dropped or scratched by hard part, please stop using the probe immediately. And contact CHISON's authorized service engineer to make sure the safety and effectiveness is in good condition before use.
13. If there is any liquid or metal to enter to the system, please power off the system and stop using it immediately. Please first contact CHISON's authorized service engineer to make sure it's safe before restart using it.
14. Please don't use solvents (such as paint thinner, benzine, or alcohol) or abrasive cleansers for cleaning the system (including monitor and probes, etc.). It may corrode the system and probes.
15. While the system or probe is over life time, please refer to operation manual section 9.5.
16. Important data must be backed up on external memory media. CHISON shall not be liable for loss of data stored in the memory of this system caused by operator error or accidents.
17. Please put this operation manual with the system to ensure operator and manager can reach it at any time.



**CAUTION:** *It is prohibited to use the device for fetal sex examination, except for necessary medical needs. The device can only be sold to qualified medical institutions or doctors. The users shall fully understand and master the devices before operating. The users shall have got the qualification, and shall comply with the local laws and regulations, the local religion and customs, etc.*



**CAUTION:** *The user should read the operation manual carefully before operating the devices. Turning on the device means the users have read the operation manual and accept the listed cautions, warnings, and notes in the manuals. If the users disagree and cannot accept the cautions, the users can ask for returning the device.*

# TABLE OF CONTENTS

DIGITAL COLOR DOPPLER ULTRASOUND SYSTEM .....	1
IMPORTANT INFORMATION .....	2
TABLE OF CONTENTS.....	5
CHAPTER 1 INTRODUCTION .....	1
1.1 System Overview.....	1
1.2 Contact Information.....	1
CHAPTER 2 SYSTEM SAFETY .....	2
2.1 Safety Overview .....	2
2.2 Electrical Safety.....	3
2.3 Labels .....	5
2.4 Patient Environmental Devices .....	8
2.5 Biological Safety .....	10
2.6 Scanning Patients and Education.....	11
CHAPTER 3 PREPARING THE SYSTEM FOR USE .....	18
3.1 Site Requirements.....	18
3.2 System Specifications.....	22
3.3 System Positioning & Transporting.....	29
3.4 Powering the System .....	30
3.5 Probes .....	33
3.6 Optional installation .....	35
3.7 User Interface Control .....	37
CHAPTER 4 IMAGING.....	48
4.1 General Description.....	48
4.2 Beginning an Exam .....	48
4.3 Optimizing the Image .....	53
4.4 After Capturing the Image.....	72
CHAPTER 5 GENERAL MEASUREMENTS.....	88
5.1 Key for Measurement .....	88
5.2 Fast measurement .....	89
5.3 Measurement and Calculation .....	92
5.4 Edit measurement results.....	134
5.5 Report.....	135
CHAPTER 6 PRESET .....	138
6.1 Recall Preset .....	138
6.2 Save user defined preset .....	138

6.3 Manage Preset .....	138
CHAPTER 7 SYSTEM SETTING.....	140
7.1 General settings.....	140
7.2 Measurement .....	145
7.3 Comment .....	147
7.4 BodyMark.....	149
7.5 Report.....	150
7.6 Admin.....	154
7.7 Network.....	155
7.8 System .....	160
CHAPTER 8 PROBES.....	168
8.1 General Description.....	168
8.2 Care and Maintenance .....	168
8.3 Probe Operation Instructions .....	179
CHAPTER 9 SYSTEM MAINTENANCE AND TROUBLESHOOTING.....	182
9.1 Back up information.....	182
9.2 System Care and Maintenance .....	182
9.3 Safety Check.....	184
9.4 Troubleshooting.....	184
9.5 Service Responsibility .....	185
APPENDIX A THE INFORMATION OF EC REPRESENTATIVE.....	188
APPENDIX B SYSTEM ONE-KEY-RECOVERY FUNCTION.....	189
APPENDIX C MAXIMUM ACOUSTIC OUTPUT REPORT .....	191
APPENDIX D TRANSDUCER MAXIMUM SURFACE TEMPERATURE.....	301
APPENDIX E GUIDANCE AND MANUFACTURER'S DECLARATION .....	302
APPENDIX F MEASUREMENT RESULTS SUMMARY .....	306

# Chapter 1 Introduction

This manual contains necessary information for safe system operation.

Read and understand all instructions in this manual before operating the system. Always keep this manual with the equipment, and periodically review the procedures for operation and safety precautions.

## 1.1 System Overview

### Indications for Use

The device is a general-purpose ultrasonic imaging instrument intended for use by a qualified physician for evaluation of Fetal, Abdominal, Pediatric, Small Organ (breast, thyroid, testes), Neonatal Cephalic, Adult Cephalic, Cardiac (adult, pediatric), Musculo-skeletal (Conventional, Superficial), Peripheral Vascular, Transesophageal, Transrectal, Transvaginal, Urology.

### Contraindication

The system is NOT intended for Ophthalmic use or any use that causes the acoustic beam to pass through the eye.

## 1.2 Contact Information

For additional information or assistance, please contact your local distributor or the appropriate support resource shown below:

CHISON website	www.chison.com
Service Support	CHISON Medical Technologies Co., Ltd. Tel: 0086-400-8878-020; 0086-0510-85311707 Fax: 0086-0510-85310726 E-mail: service@chison.com.cn
Placing an Order	CHISON Medical Technologies Co., Ltd. Tel: 0086-0510-8531-0593/0937 Fax: 0086-0510-85310726 Email: export@chison.com.cn
Manufacturer	CHISON Medical Technologies Co., Ltd. No.3 Changjiang South Road, Xinwu District, Wuxi, 214028 Jiangsu, P.R. China
US Agent	Mr. Marco Mu, 2219 Rimland Drive, Suite 301, Bellingham, Barkley Villiage Bellingham, Washington, 98226, UNITED STATES Phone: 360-3257028, Fax: 360-9253199, Email: us.agent@mid-link.net MID-LINK INTERNATIONAL CO., LTD

 **CAUTION: Federal law restricts the device to sale by or on the order of a licensed practitioner or therapist.**

## Chapter 2 System Safety

### 2.1 Safety Overview

This section discusses the measures to ensure the safety of both the operator and patient. To ensure the safety of both operator and patient, please read the relevant details in this chapter carefully before operating this system. Disregarding the warnings or violation of relevant rules may result in personal injury for operator or patient, or even loss of life.

Users should observe the following precautions:

- This system complies with Type BF general equipment, and the IEC standard. Please follow Chapter 2 “System Safety” in the operation manual to use this system properly.
- Please do not modify this system in any way. If modifications are necessary, please contact the manufacturer first to get more information and permission.
- This system has been fully adjusted at the factory. Do not adjust any fixed adjustable parts.
- In the event of a malfunction, turn off the system immediately and inform the manufacturer or its designated agents.
- The power cord of the system should be connected to a grounded power socket. Do not remove the ground cable for any reason.
- Only connect this system, either electronically or mechanically, with devices that comply with the IEC/EN60601-1 standard. Recheck the leakage current and other safety performance indices of the entire system to avoid potential system damage caused by leakage from a current superposition.
- The system does not incorporate any specialized protective measures in the event it is configured with high-frequency operation devices. The operator should use caution in these types of applications.
- The system should be installed only by personnel authorized by the manufacturer. Do not attempt to install the system by yourself.
- Only a CHISON's authorized service engineer can perform maintenance.
- Only a qualified operator, or someone under qualified supervision, can use the system.
- Do not use this system in the presence of flammable substances, otherwise an explosion may occur.
- Do not continuously scan the same part of a patient or expose the patient to prolonged scanning. Otherwise, it may harm the patient.
- When using the system for ultrasound testing, only use qualified ultrasound gel that complies with system standards.
- Do not unplug probe when the system is in active operation. Always go to transducer Selection screen when need to remove the probe.
- To prevent from arm or neck injury, the operator should not stay at the same position for too long during patient scanning without taking break.
- Do not put liquid on top of the main unit.



**To dispose of this product properly, please contact the local CHISON's Authorized Service Representative.**

## 2.2 Electrical Safety

Type of protection against electric shock

### Class I Equipment

CLASS I EQUIPMENT in which protection against electric shock does not rely on basic insulation only, but which includes an additional safety precaution in that accessible conductive parts are connected to the protective earthing conductor in the electrical installation in such a way that accessible parts cannot become live in the event of a failure of the basic insulation.

### Degree of protection against electric shock

- Type BF Applied part (for Probes marked with BF symbol)

TYPE BF APPLIED PART providing a specified degree of protection against electric shock, with particular regard to allowable LEAKAGE CURRENT

### Level of protection against harmful ingress of water

- Parts of **probe** likely to come into contact with **operator** or **patient** meet the requirements of **drip-proof equipment (IPX1)**  
Parts of **probe** intended to be immersed in **normal use** meet the requirements of **watertight equipment (IPX7)**
- The IP Classification of System is Ordinary Equipment (IPX0)  
The Equipment is not suitable for use in the presence of a flammable anesthetic mixed with air (with oxygen or with oxide)

### Mode of operation

- Continuous Operation  
For maximum safety, always follow these guidelines:
  - Proper grounding of the system is critical to avoid electric shock. For protection, ground the chassis with a three-wire cable, and plug the system into three-hole outlet.
  - Do not remove or circumvent the grounding wire.
  - Do not remove the protective covers on the system. These covers protect users against hazardous voltages. Cabinet panels must remain in place while the system is in use. A qualified electronic technician must make all internal replacements.
  - Do not operate this system in the presence of flammable gases or anesthetics.
  - All peripheral devices (unless certified as medical grade) that are connected to the system

must be powered through the electrical outlet with an optional isolation transformer.

- Suggest power off the system in 30 minutes if the system continuously works in 8 hours.

### Notice upon Installation of Product

Separation distance and effect from fixed radio communications equipment: field strengths from fixed transmitters, such as base stations for radio (cellular/cordless) telephones and land mobile radios, amateur radio, AM and FM radio broadcast, and TV broadcast transmitter cannot be predicted theoretically with accuracy. To assess the electromagnetic environment due to fixed RF transmitters, an electromagnetic site survey should be considered. If the measured field strength in the location in which the ultrasound system is used exceeds the applicable RF compliance level as stated in the immunity declaration, the ultrasound system should be observed to verify normal operation. If abnormal operation is observed, additional measures may be necessary, such as re-orienting or relocating the ultrasound system or using an RF shielded examination room may be necessary.

- Use either power supply cords provided by or designated by CHISON. Products equipped with a power source plug should be plugged into the fixed power socket which has the protective grounding conductor. Never use any adaptor or converter to connect with a power source plug (e.g. three-prong-to-two-prong converter).
- Locate the equipment as far away as possible from other electronic equipment.
- Be sure to only use the cables provided by or designated by CHISON. Connect these cables following the installation procedures (e.g. wire power cord separately from signal cables).
- Lay out the main equipment and other peripherals following the installation procedures described in this manual.

### Notice against User Modification

The user should never modify this product.

User modifications may cause degradation in Electrical Safety. Modification of the product includes changes in:

- Cables (length, material, wiring, etc.)
- System configuration/components
- User modifications may cause degradation in EMC performance. Modification of the product includes changes in:
  - Cables (length, material, wiring, etc.)
  - System installation/layout
  - System configuration/components
  - Securing system parts (cover open/close, cover screwing)

## 2.3 Labels

# CHISON

### Digital Color Doppler Ultrasound System

MODEL : CBit 4

P/N : 95-00454-80

INPUT : 100-240V~, 50-60Hz, 600VA max.

SN

  
YYYY-MM

 **CHISON Medical Technologies Co., Ltd.**  
No.3, Changjiang South Road,  
Xinwu District, Wuxi,  
214028 Jiangsu,  
P.R.China

EC REP

Rx only





 0197











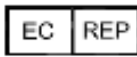

Shanghai International Holding Corp.GmbH(Europe)  
Eiffestrasse 80,20537 Hamburg, Germany















Fig.2-1Rear panel label

### 2.3.1 Symbols on label

 <p><b>WASTE OF ELECTRICAL AND ELECTRONIC EQUIPMENT (WEEE):</b> This symbol is used for Environment Protection, it indicates that the waste of electrical and electronic equipment must not be disposed as unsorted waste and must be collected separately. Please contact your local Authority or distributor of the manufacturer for information concerning the decommissioning of your equipment.</p>	 <p>This mark indicates that this product contains a limited amount of hazardous substances in the Chinese Standard GB/T 26572-2011 "Limited Requirements for Restricted Substances in Electrical and Electronic Products". The numbers in the logo are the environmental protection use period of the product, indicating that under the normal use conditions, the harmful substances will not leak or be abrupt. The use of the product will not cause serious pollution to the environment or cause personal or property serious damage, the term unit is year.</p>
 <p>Do not use the following devices near this</p>	 <p>Caution, consult accompanying documents.</p>

<p>equipment: cellular phone, radio receiver, and mobile radio transmitter, radio controlled toy, etc. Use of these devices near this equipment could cause this equipment to perform outside the published specifications. Keep these devices power off when near this equipment.</p>	<p>This symbol advises the reader to consult the accompanying documents for important safety related information such as warnings and precautions that Cannot be presented on the device itself.</p>
<p> This symbol is followed by the manufacturing date of the device in the form YYYY-MM.</p>	<p> The CE mark of Conformity indicates this equipment conforms with the Council Directive 93/42/EEC</p>
<p> AUTHORIZED REPRESENTATIVE IN THE EUROPEAN COMMUNITY: This symbol is accompanied by the name and the address of the authorized representative in the European Community.</p>	<p> Insulated patient application part (Type BF)</p>
<p> This symbol is followed by the serial number of the device.</p>	<p> <b>MANUFACTURER:</b> This symbol is accompanied by the name and the address of the manufacturer.</p>
<p> Potential equilibrium connection</p>	<p> Main power switch ON</p>
<p> Main power switch OFF</p>	<p> Power On/off.          Power On: the main unit connects to the adapter with power supply, the battery start charge.          Poweroff: the main unit disconnects to the adapter with power supply, the battery end charge.  <b>CAUTION:</b> This Power Switch DOES NOT ISOLATE Mains Supply.</p>
<p> The "Alternating current" symbol indicates that the equipment is suitable for alternating current only.</p>	<p> Refer to instruction manual.</p>

<p><b>IPX7</b> Protection against the effects of immersion (probes)</p>	<p><b>IPX0</b> No protection against ingress of water (system)</p>
<p><b>Rx only</b> This symbol indicates that in the united states of America, Federal law restricts the device to sale by or on the order of a licensed practitioner or therapist.</p>	<p> Sleep Indicator: When the system is sleep, the indicator lights, otherwise extinguishes.</p>
<p> Adapter Indicator: when the main unit connects to the adapter with power supply, the indicator lights, otherwise extinguishes.</p>	<p> Charge Indicator: When the battery is charging, the indicator flashes once every three seconds, when the battery is lower capacity, the indicator flashes once every second.</p>
<p> Show the State of charging and remaining electric quantity</p>	<p> Show the State of discharge and remaining electric quantity and available time.</p>
<p> Be careful, arrow area may Clamp hand!</p>	<p> Please read the user handbook Before operation.</p>
<p> In the process of push down the monitor, it is forbidden to place items to this region, otherwise there is oppression may flip monitor.</p>	<p> Forbidden to push the monitor to move the machine.</p>
<p> Forbidden to place heavy objects on the monitor after push down the monitor.</p>	<p> Forbidden to press the monitor after push down the monitor.</p>
<p> Forbidden to put the hand at the bottom of the monitor when turning the monitor.</p>	<p> This part it is forbidden to impose extra upward or downward force (especially when transporting need to up and down movement machine)</p>

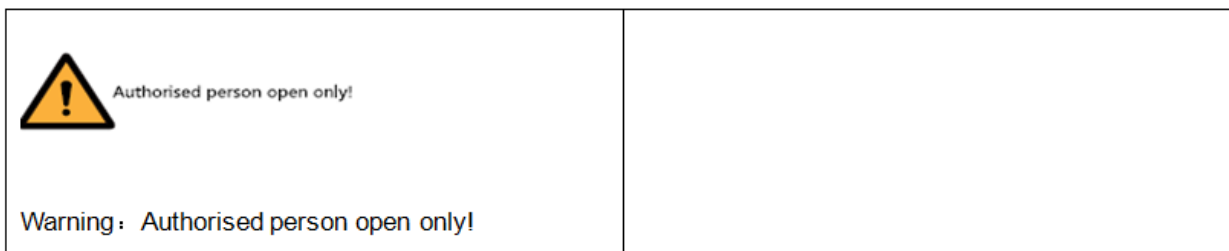

## 2.4 Patient Environmental Devices

Front side (refer to Fig. 3-1 b in Chapter 3):

- DVD RW

Right side (refer to Fig. 3-1 c in Chapter 3):

- 3 Probe ports
- 2 USB ports on control panel

Rear panel (refer to Fig.3-1d in Chapter3) :

- 4 USB ports
- 1 LAN port
- 1 Remote port
- 1 S-VIDEO port
- L/R AUDIO port
- 1 DVI port
- 1 VGA port
- 1 VIDEO port
- 2 Foot-switch ports

### Acceptable Devices

The Patient Environmental devices shown above are specified to be suitable for use within the PATIENT ENVIRONMENT.

### **CAUTION:**

- ***DO NOT connect any probes or accessories without approval by CHISON within the PATIENT ENVIRONMENT.***
- ***DO NOT touch patient and devices without IEC/EN 60601-1 approval to avoid the leakage current risk within the PATIENT ENVIRONMENT.***

### Unapproved Devices

### **CAUTION:**

- ***DO NOT use unapproved devices.***
- ***If devices are connected without the approval of CHISON, the warranty will be INVALID.***
- ***The system can't be used with HF surgical equipment; otherwise the burns***

**to patient may occur.**

- **Any device connected to this system must conform to one or more of the requirements listed below:**
  - IEC standard or equivalent standards appropriate to devices.**
  - The devices shall be connected to PROTECTIVE EARTH (GROUND).**



**CAUTION: Unsafe operation or malfunction may occur. Use only the accessories, options and supplies approved or recommended in these instructions for use.**

#### Peripheral used in the patient environment

The system has been verified for overall safety, compatibility and compliance with the following on-board image recording devices:

B/W video printer: Mitsubishi P93W, Sony UP-711MD, Sony UP-X898MD

Color video printer: Mitsubishi CP31W

The system may also be used safely while connected to devices other than those recommended above if the devices and their specifications, installation, and interconnection with the system conform to the requirements of IEC/EN 60601-1.

The connection of equipment or transmission networks other than as specified in the user instructions can result in an electric shock hazard or equipment malfunction. Substitute or alternate equipment and connections require verification of compatibility and conformity to IEC/EN 60601-1 by the installer. Equipment modifications, possible resulting malfunctions and electromagnetic interference are the responsibilities of the owner.

General precautions for installing an alternate off-board, remote device or a network would include:

- The added device(s) must have appropriate safety standard conformance and CE Marking.
- There must be adequate mechanical mounting of the device and stability of the combination.
- Risk and leakage current of the combination must comply with IEC/EN 60601-1.
- Electromagnetic emissions and immunity of the combination must conform to IEC/EN 60601-1-2.

#### Peripheral used in the non-patient environment

The system has been verified for compatibility, and compliance for connection to a local area network (LAN) via a wire LAN. The provided LAN components are IEC/EN 60950 compliant.

General precautions for installing an alternate off-board, remote device or a network would include:

- The added device(s) must have appropriate safety standard conformance and CE Marking.

The added device(s) must be used for their intended purpose having a compatible interface.



**CAUTION: Make sure using ONLY the dedicated USB disk or removable media to save or back up data. Before connecting to the ultrasound system, make sure using the latest antivirus software on the USB disk or removable media to clean any virus. It is user's responsibility to ensure the USB disk or removable**

**media is virus-free. Improper use of USB disk or removable media may cause the virus infections of system and eventually malfunction may occur. Such malfunction may impact the stability, effectiveness and safety of the system and probes, and users should immediately stop using the system and probes until CHISON authorized engineer has checked the system and confirm the effectiveness and safety of the system and probes.**



**CAUTION: Use only secure Local Area Network connection. Don't connect the ultrasound system to Internet. Make sure your hospital's firewall software is configured correctly, thus blocking incoming connection requests from Internet. Improper use of network connection may cause the virus infections of system and eventually malfunction may occur.**

## 2.5 Biological Safety

This product, as with all diagnostic ultrasound equipment, should be used only for valid reasons and should be used both for the shortest period of time and at the lowest power settings necessary (ALARA - As Low As Reasonably Achievable) to produce diagnostically acceptable images. The AIUM offers the following guidelines:

### **Clinical Safety Quoted from AIUM**

Approved March 26, 1997

Diagnostic ultrasound has been in use since the late 1950s. Given its known benefits and recognized efficacy for medical diagnosis, including use during human pregnancy, the American Institute of Ultrasound in Medicine herein addresses the clinical safety of such use:

There are no confirmed biological effects on patients or instrument operators caused by exposures from present diagnostic ultrasound instruments. Although the possibility exists that such biological effects may be identified in the future, current data indicate that the benefits to patients of the prudent use of diagnostic ultrasound outweigh the risks, if any that may be present.

**Heating:** Elevating tissue temperature during obstetrical examinations creates medical concerns. At the embryo development stage, the rise in temperature and the length of time exposed to heat combine to determine potential detrimental effects. Exercise caution particularly during Doppler/Color exams. The Thermal Index (TI) provides a statistical estimate of the potential temperature elevation (in centigrade) of tissue temperature. Three forms of TI are available: Soft Tissue Thermal Index (TIS), Bone Thermal Index (TIB) and Cranial Bone Thermal Index (TIC).

Soft Tissue Thermal Index (TIS). Used when imaging soft tissue only, it provides an estimate of

potential temperature increase in soft tissue.

Bone Thermal Index (TIB). Used when bone is near the focus of the image as in the third trimester OB examination, it provides an estimate of potential temperature increase in the bone or adjacent soft tissue.

Cranial Bone Thermal Index (TIC). Used when bone is near the skin surface as in transcranial examination, it provides an estimate of potential temperature increase in the bone or adjacent soft tissue.

**Cavitations:** Cavitations may occur when sound passes through an area that contains a cavity, such as a gas bubble or air pocket (in the lung or intestine, for example). During the process of cavitations, the sound wave may cause the bubble to contract or resonate. This oscillation may cause the bubbles to explode and damage the tissue. The Mechanical Index (MI) has been created to help users accurately evaluate the likelihood of cavitations and the related adverse effects.

MI recognizes the importance of non-thermal processes, cavitations in particular, and the Index is an attempt to indicate the probability that they might occur within the tissue.

## 2.6 Scanning Patients and Education

The Track-3 or IEC60601-2-37 output display standard allows users to share the responsibility for the safe use of this ultrasound system. Follow these usage guidelines for safe operation:

- In order to maintain proper cleanliness of the probes, always clean them between patients.
- Always use a disinfected sheath on all EV/ER probes during every exam.
- Continuously move the probe, rather than staying in a single spot, to avoid elevated temperatures in one part of the patient's body.
- Move probe away from the patient when not actively scanning.
- Understand the meaning of the TI, TIS, TIB, TIC and MI output display, as well as the relationship between these parameters and the thermal/cavitation bioeffect to the tissue.
- Expose the patient to only the very lowest practical transmit power levels for the shortest possible time to achieve a satisfactory diagnosis (ALARA - As Low As Reasonably Achievable).

### 2.6.1 Safe Scanning Guidelines

- Ultrasound should only be used for medical diagnosis and only by trained medical personnel.
- Diagnostic ultrasound procedures should be done only by personnel fully trained in the use of the equipment, in the interpretation of the results and images, and in the safe use of ultrasound (including education as to potential hazards to the patient and the operator).
- Operators should understand the likely influence of the machine controls, the operating mode (e.g. B-mode, color Doppler imaging or spectral Doppler) and probe frequency on thermal and cavitations hazards.

- Select a low setting for each new patient. Output should only be increased during the examination if penetration is still required to achieve a satisfactory result, and after the Gain control has been adjusted to its maximum value.
- Maintain the shortest examination time necessary to produce a useful diagnostic result.
- Do not hold the probe in a fixed position for any longer than is necessary. It should be removed from the patient whenever there is no need for real-time imaging or spectral Doppler acquisition. The frozen frame and Cine loop capabilities allow images to be reviewed and discussed without exposing the patient to continuous scanning.
- Do not use endo-cavitary probes if there is noticeable self heating of the probe when operating in the air. Although applicable to any probe, take particular care during trans-vaginal exams during the first eight weeks of gestation.
- Take particular care to reduce output and minimize exposure time of an embryo or fetus when the temperature of the mother is already elevated.
- Take particular care to reduce the risk of thermal hazard during diagnostic ultrasound when exposing: an embryo less than eight weeks after gestation; or the head, brain or spine of any fetus or neonate.
- Operators should continually monitor the on-screen thermal index (TI) and mechanical index (MI) values and use control settings that keep these settings as low as possible while still achieving diagnostically useful results. In obstetric examinations, TIS (soft tissue thermal index) should be monitored during scans carried out in the first eight weeks after gestation, and TIB (bone thermal index) thereafter. In applications where the probe is very close to bone (e.g. trans-cranial applications), TIC (cranial bone thermal index) should be monitored.

MI > 0.3

There is a possibility of minor damage to neonatal lung or intestine. If such exposure is necessary, reduce the exposure time as much as possible.

MI > 0.7

There is a risk of cavitations if an ultrasound contrast agent containing gas micro-spheres is being used. There is a theoretical risk of cavitations without the presence of ultrasound contrast agents. The risk increases with MI values above this threshold.

TI > 0.7

The overall exposure time of an embryo or fetus should be restricted in accordance with Table 2-2 below as a reference:

TI	Maximum exposure time (minutes)
0.7	60
1.0	30
1.5	15
2.0	4
2.5	1

Table 2-2 Maximum recommended exposure times for an embryo or fetus

- Non-diagnostic use of ultrasound equipment is not generally recommended. Examples of non-diagnostic uses of ultrasound equipment include repeated scans for operator training, equipment demonstration using normal subjects, and the production of souvenir pictures or videos of a fetus. For equipment of which the safety indices are displayed over their full range of values, the TI should always be less than 0.5 and the MI should always be less than 0.3. Avoid frequent repeated exposure of any subject. Scans in the first trimester of pregnancy should not be carried out for the sole purpose of producing souvenir videos or photographs, nor should their production involve increasing the exposure levels or extending the scan times beyond those needed for clinical purposes.
- Diagnostic ultrasound has the potential for both false positive and false negative results. Misdiagnosis is far more dangerous than any effect that might result from the ultrasound exposure. Therefore, diagnostic ultrasound system should be performed only by those with sufficient training and education.

## 2.6.2 Understanding the MI/TI Display

Track-3 follows the Output Display Standard for systems that include fetal Doppler applications. The acoustic output will not be evaluated on an application-specific basis, but the global maximum de-rated  $I_{spta}$  must be  $\leq 720 \text{ mW/cm}^2$  and either the global maximum MI must be  $\leq 1.9$  or the global maximum de-rated  $I_{sppa}$  must be  $\leq 190 \text{ W/cm}^2$ . An exception is for ophthalmic use, in which case the  $TI = \max(TIS_{as}, TIC)$  is not to exceed 1.0;  $I_{spta.3} \leq 50 \text{ mW/cm}^2$ , and  $MI \leq 0.23$ . Track-3 gives the user the freedom to increase the output acoustic power for a specific exam, and still limit output acoustic power within the global maximum de-rated  $I_{spta} \leq 720 \text{ mW/cm}^2$  under an Output Display Standard.

For any diagnostic ultrasonic systems, Track-3 provides an Output Indices Display Standard. The diagnostic ultrasound systems and its operation manual contain the information regarding an ALARA (As Low As Reasonably Achievable) education program for the clinical end-user and the acoustic output indices, MI and TI. The MI describes the likelihood of cavitations, and the TI offers the predicted maximum temperature rise in tissue as a result of the diagnostic examination. In general, a temperature increase of  $2.5^\circ\text{C}$  must be present consistently at one

spot for 2 hours to cause fetal abnormalities. Avoiding a local temperature rise above 1°C should ensure that no thermally induced biologic effect occurs. When referring to the TI for potential thermal effect, a TI equal to 1 does not mean the temperature will rise 1 degree C. It only means an increased potential for thermal effects can be expected as the TI increases. A high index does not mean that bioeffects are occurring, but only that the potential exists and there is no consideration in the TI for the scan duration, so minimizing the overall scan time will reduce the potential for effects. These operator control and display features shift the safety responsibility from the manufacturer to the user. So it is very important to have the Ultrasound systems display the acoustic output indices correctly and the education of the user to interpret the value appropriately.

**RF: (De-rating factor)**

In Situ intensity and pressure cannot currently be measured. Therefore, the acoustic power measurement is normally done in the water tank, and when soft tissue replaces water along the ultrasound path, a decrease in intensity is expected. The fractional reduction in intensity caused by attenuation is denoted by the de-rating factor (RF),

$$R_F = 10^{(-0.1 a f z)}$$

Where a is the attenuation coefficient in dB cm<sup>-1</sup> MHz<sup>-1</sup>, f is the transducer center frequency, and z is the distance along the beam axis between the source and the point of interest.

De-rating factor R<sub>F</sub> for the various distances and frequencies with attenuation coefficient 0.3dB cm<sup>-1</sup> MHz<sup>-1</sup> in homogeneous soft tissue is listed in the following table. An example is if the user uses 7.5MHz frequency, the power will be attenuated by .0750 at 5cm, or 0.3x7.5x5=-11.25dB. The De-rated Intensity is also referred to as 'I<sub>s</sub>' at the end (e.g. Ispta.3).

Distance (cm)	Frequency (MHz)			
	1	3	5	7.5
1	0.9332	0.8128	0.7080	0.5957
2	0.8710	0.6607	0.5012	0.3548
3	0.8128	0.5370	0.3548	0.2113
4	0.7586	0.4365	0.2512	0.1259
5	0.7080	0.3548	0.1778	0.0750
6	0.6607	0.2884	0.1259	0.0447
7	0.6166	0.2344	0.0891	0.0266
8	0.5754	0.1903	0.0631	0.0158

I<sub>s</sub>=I\*R<sub>F</sub> Where I' is the intensity in soft tissue, I<sub>s</sub> is the time-averaged intensity measured in water.

**Tissue Model:**

Tissue temperature elevation depends on power, tissue type, beam width, and scanning mode. Six models are developed to mimic possible clinical situations.

	Thermal Models	Composition	Mode	Specification	Application
1	TIS	Soft tissue	Unscanned	Large aperture (>1cm <sup>2</sup> )	Liver PW
2	TIS	Soft tissue	Unscanned	Small aperture (<1cm <sup>2</sup> )	Pencil Probe
3	TIS	Soft tissue	Scanned	Evaluated at surface	Breast color
4	TIB	Soft tissue and bone	Scanned	Soft tissue at surface	Muscle color
5	TIB	Soft tissue and bone	Unscanned	Bone at focus	Fetus head PW
6	TIC	Soft tissue and bone	Unscanned/scanned	Bone at surface	Transcranial

Soft tissue:

Describes low fat content tissue that does not contain calcifications or large gas-filled spaces.

Scanned: (auto-scan)

Refers to the steering of successive burst through the field of view, e.g. B and color mode.

Unscanned:

Emission of ultrasonic pulses occurs along a single line of sight and is unchanged until the transducer is moved to a new position. For instance, the PW, and M mode.

TI:

TI is defined as the ratio of the In Situ acoustic power ( $W_{.3}$ ) to the acoustic power required to raise tissue temperature by 1°C ( $W_{deg}$ ),  $TI = W_{.3}/W_{deg}$ .

Three TIs corresponding to soft tissue (TIS) for abdominal; bone (TIB) for fetal and neonatal cephalic; and cranial bone (TIC) for pediatric and adult cephalic, have been developed for applications in different exams.

An estimate of the acoustic power in milli-watts necessary to produce a 1°C temperature elevation in soft tissue is:

$$W_{deg} = 210/f_c, \quad \text{for model 1 to 4, where } f_c \text{ is the center frequency in MHz.}$$

$$W_{deg} = 40 K D \quad \text{for model 5 and 6, where } K \text{ (beam shape factor) is } 1.0, D \text{ is the aperture diameter in cm at the depth of interest.}$$

MI:

Cavitation is more likely to occur at high pressures and low frequencies in pulse ultrasound wave in the tissue, which contains the bubble or air pocket (for instance, the lung, intestine, or scan with gas contrast agents). The threshold under optimum conditions of pulsed ultrasound is predicted by the ration of the peak pressure to the square root of the frequency.

$$MI = Pr' / \text{sqrt}(f_c)$$

$Pr'$  is the de-rated (0.3) peak rare-fractional pressure in Mpa at the point where  $PII$  is the maximum, and  $f_c$  is the center frequency in MHz.  $PII$  is the Pulse Intensity Integral that the total energy per unit area carried by the wave during the time duration of the pulse. The peak rare- fractional pressure is measured in hydrophone maximum negative voltage

normalized by the hydrophone calibration parameter.

### Display Guideline:

For different operation modes, different indices must be displayed. However, only one index needs to be shown at a time. Display is not required if maximum MI is less than 1.0 for any setting of the operating mode, or if maximum TI is less than 1.0 for any setting of the operating mode. For TI, if the TIS and TIB are both greater than 1.0, the scanners need not be capable of displaying both indices simultaneously. If the index falls below 0.4, no display is needed. The display increments are no greater than 0.2 for index value less than one and no greater than 1.0 for index values greater than one (e.g. 0.4, 0.6, 0.8, 1, 2, 3).

### Display and Report in Different Mode

Located on the upper middle section of the system display monitor, the acoustic output display provides the operator with real-time indication of acoustic levels being generated by the system.

For B-Scan Mode

Only display and report MI, and start from 0.4 if maximum MI > 1.0, display in increments of 0.2.

For Color Mode

Only display and report TIS or TIB and start from 0.4 if maximum TI > 1.0, display in increments of 0.2 for values of indices of 2.0 or less, and 0.5 for values of indices greater than 2.0.

For Doppler Mode

Only display and report TIS or TIB and start from 0.4 if maximum TI > 1.0, display in increments of 0.2 for values of indices of 2.0 or less, and 0.5 for values of indices greater than 2.0.

Below is a simple guideline for the user when TI exceeds one limit exposure time to  $4^{(6-TI)}$  minutes based on the 'National Council on Radiation Protection. Exposure Criteria for Medical Diagnostic Ultrasound: I. Criteria Based on Thermal Mechanisms. Report No.113 1992'.

### Operator Control Features:

The user should be aware that certain operator controls may affect the acoustic output. It is recommended to use the default (or lowest) output power setting and compensate using Gain control to acquire an image. Other than the output power setting in the soft-menu, which has the most direct impact on the power; the PRF, image sector size, frame rate, depth, and focal position also slightly affect the output power. The default setting is normally around 70% of the allowable power depending on the exam application mode.

### Controls Affecting Acoustic Output

The potential for producing mechanical bioeffects (MI) or thermal bioeffects (TI) can be influenced by certain controls.

Direct: The Acoustic Output control has the most significant effect on Acoustic Output.

Indirect: Indirect effects may occur when adjusting controls. Controls that can influence MI and TI

are detailed under the bioeffect portion of each control in the Optimizing the Image chapter. Always observe the Acoustic Output display for possible effects.

### Best practices while scanning

**HINTS:** Raise the Acoustic Output only after attempting image optimization with controls that have no effect on Acoustic Output, such as Gain and TGC.



**WARNING: Be sure to have read and understood control explanations for each mode used before attempting to adjust the Acoustic Output control or any control that can affect Acoustic Output.**

Use the minimum necessary acoustic output to get the best diagnostic image or measurement during an examination. Begin the exam with the probe that provides an optimum focal depth and penetration.

### Acoustic Output Default Levels

In order to assure that an exam does not start at a high output level, the system initiates scanning at a reduced default output level. This reduced level is preset programmable and depends upon the exam icon and probe selected. It takes effect when the system is powered on or New Patient is selected. To modify acoustic output, adjust the Power Output level on the Soft Menu.

## Chapter 3 Preparing the System for Use

### 3.1 Site Requirements

#### 3.1.1 Operation Environmental Requirements

The following environmental conditions are within system tolerances for operation:

Temperature:	10° C ~ 40° C
Relative Humidity:	30%~75%, non-condensing
Atmosphere Pressure:	700hPa ~ 1060hPa

Strong radiation sources or powerful electromagnetic waves (e.g. electro-magnetic waves from radio broadcasting) may result in image ghosting or noise. The system should be isolated from such radiation sources or electromagnetic waves.

To prevent damage to the system, do not use in the following locations:

- Exposed to direct sunlight
- Subject to sudden changes in temperature
- Dusty
- Subject to vibration
- Near heat generators
- High humidity



- ***This equipment generates, uses and can radiate radio frequency energy. The equipment may cause radio frequency interference to other medical and non-medical devices and radio communications. To provide reasonable protection against such interference, this product complies with emissions limits for a Group 1, Class A Medical Devices Directive as stated in IEC/EN 60601-1-2. However, there is no guarantee that interference will not occur in a particular installation.***
- ***If this equipment is found to cause interference (which may be determined by turning the equipment on and off), the user (or qualified service personnel) should attempt to correct the problem by one or more of the following measure(s):***
  - ***reorient or relocate the affected device(s).***
  - ***increase the separation between the equipment and the affected device.***
  - ***power the equipment from a source different from that of the affected device.***
  - ***consult the point of purchase or service representative for further suggestions.***

#### 3.1.2 Transport and Storage Environmental Requirements

The following environmental transport and storage conditions are within system tolerances:

Temperature:	-5° C ~ 40° C
--------------	---------------

Relative Humidity: ≤80% non-condensing

Atmosphere Pressure: 700hPa ~ 1060hPa

### 3.1.3 Electrical Requirements

Power Requirements

AC 100-240V, 50-60Hz

Fuse Requirements

Fuse specification is 250V, 5.0 A (time-lag), the model is 50T T5AL 250V



**CAUTION: Please use the fuse provided by manufactory if the fuse need replace. User can't buy and exchange the fuse by themselves.**

Power Consumption: 600VA max.

Voltage Fluctuation



**WARNING: Maintain a fluctuation range of less than ±10% of voltage labeling on rear panel of the system, otherwise the system may be damaged.**

Grounding

Before connecting the power cord, connect the attached ground protection cable from Equipotentiality terminal on system rear panel to a specialized grounding device.



**NOTE:**

- ***Please follow the outlined power requirements. Only use power cords that meet the system guidelines—failure to follow these procedures may result in system damage.***
- ***Line power may vary in different geographic locations. Refer to the detailed ratings on the rear panel of the system for detailed information.***

Built in battery specifications

Battery model	BT-2000	
Capacity	9000mAh	
Rated voltage	14.4V	
Standard charge voltage	16.8V	
Discharge closing voltage	11V	
Discharge time	About 90 minutes	
Standard charge current	1800mA	
Maximum continuous discharge current	9000mA	
Battery structure	4S3P	
Cycle life	300 times	
Charging time	About 150 minutes	
Operating temperature	Charge	0°C ~ 55°C
	Discharge	-20°C ~ 65°C
	Storage	-20°C ~ 60°C for less than 1 months; -20°C ~ 30°C for less than 6 months
Battery status indicator	1%-100%	Power balance display
	Charge tips	Charge indicator

Adapter specifications

Adapter model	MINT1150
Input	100-240V~2A, 47-63Hz
Output	18.5V= 8.33A

 **NOTE:**

**To avoid the battery bursting, igniting, or fumes from the battery to cause the equipment damage.**

**Do observe the following precautions:**

- 1) Do not immerse the battery in water or allow it to get wet.**
- 2) Do not put the battery into a microwave oven or pressurized container.**
- 3) If the battery leaks or emits an odor, remove it from all possible flammable sources.**
- 4) If the battery emits an odor or heat, is deformed or discolored, or in a way appears abnormal during use, recharging or storage, immediately remove it and stop using it.**
- 5) The battery shall be storied within -10 °C~ 45 °C range environmental condition .If stored**

*for a long time (exceed three months), the cell should be stored in dry and cooling place. The cell's storage voltage should be 14.0~14.8V and the cell is to be stored in a condition as Temperature: 23±5 °C, Humidity: 65±20 %RH.*

- 6) Upon receipt of the CBit 4 and before first time usage, it is highly recommended that the customer performs one full discharge/charge cycle. If the battery has not been used for over 2 months, the customer is recommended to perform one full discharge/charge cycle. One Full Discharge/Charge Cycle Process: 1. Full discharge of battery to let the CBit 4 automatically shut down. 2. Charge the CBit 4 to 100% FCC (full current capacity). When storing packs for more than 3 months, charge the pack at least once during the 3 month timeframe to prevent leakage and deterioration in performance.*
- 7) Do not dismantle the battery. If need to change the battery, please contact CHISON's authorized service engineer.*
- 8) To avoid the battery bursting, igniting, or fumes from the battery to cause the equipment damage.*

 **CAUTION:**

- 1. Do not immerse the battery in water or allow it to get wet.*
- 2. Do not use or store the battery near sources of heat such as a fire or heater.*
- 3. Do not use any chargers other than those recommended.*
- 4. Do not put the battery into a fire or apply direct heat to it.*
- 5. Do not short-circuit the battery by connecting wires or other metal objects to the positive (+) and negative (-) terminals.*
- 6. Do not pierce the battery casing with a nail or other sharp object, break it open with a hammer, or step on it.*
- 7. Do not strike, throw or subject the battery to sever physical shock.*
- 8. Do not attempt to disassemble or modify the battery in any way.*
- 9. Do not place the battery in a microwave oven or pressurized container.*
- 10. Do not use the battery if it gives off an odor, generates heat, becomes discolored or deformed, or appears abnormal in any way. If the battery is in use or being recharged, remove it from the device or charger immediately and discontinue use.*
- 11. Do not use or store the battery where is exposed to extremely hot, such as under window of a car in direct sunlight in a hot day. Otherwise, the battery may be overheated. This can also reduce battery performance and/or shorten service life.*
- 12. If the battery leaks and electrolyte gets in your eyes, do not rub them. Instead, rinse them with clean running water and immediately seek medical attention. If left as is, electrolyte can cause eye injury.*

## 3.2 System Specifications

### 3.2.1 Console Overview



Fig. 3-1 a: Console Overview

The following pictures show the system in different views.

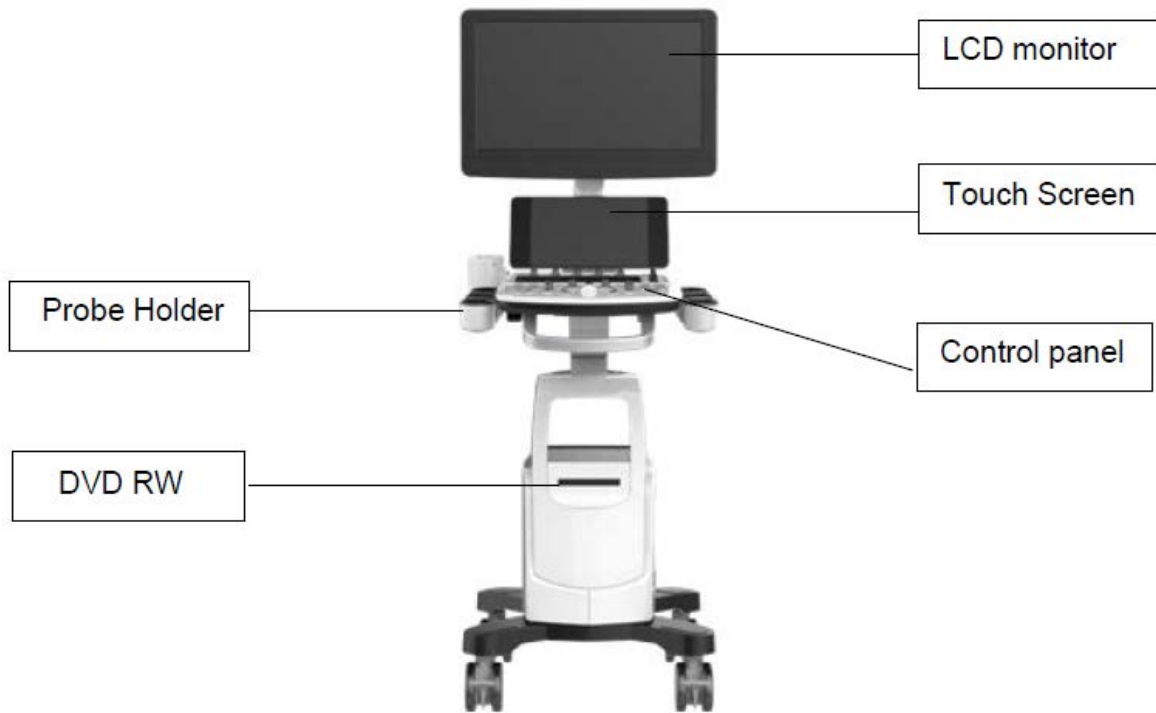

Fig. 3-1 b: Front Side View



Fig. 3-1 c: Right Side View



### 3.2.3 Key System Features

- Display B, B/M, M, B/B, 4B, 2D Steer, CFM, CPA, DPD, PW, B/BC, Triplex, Quadplex, HD 3D, CW, Free Steering M, HPRF, TDI, Color M, Curved Panoramic, FHI, Trapezoid Image, Elastography, 4D, Virtual HD
- Zoom and depth adjustment.
- Set the total gain, contrast, frequency band, 8 segments of TGC, dynamic range, persistence.
- Image post-processing of raw data: measurement and zoom after freezing the image.
- 256 gray-scale image display technology, Q-image technology, stable performance, high resolution.
- Image freezing and storage function; the stored images can be recalled for analysis.
- Storage file format: single and movie file formats
- Scanning direction can be changed and the image can be reversed in left/right, up/down direction.
- Distance, area, circumference, volume, fetal weight, heart rate etc. measurements are available and automatic calculation of OB, cardiology are available. direct display of gestation age and expected date of child delivery.
- Elliptical method and tracing method are provided for area/circumference measurement
- Many kinds of body marks can be displayed together with corresponding probe position indication.
- Comment function in image area of the screen, special comment terms for different exam mode can be added according to user's requirement.
- Display of Patient ID, Time and Date display according to real-time clock.
- Trackball available for operation and measurement. Characters can be input directly by keyboard.
- When one function is under operation, the corresponding key on the control panel will be brightly lit. When exiting from the function, the corresponding key on the control panel will be slightly lit.
- Measure the percentage of stenosis, blood flow velocity, velocity ratio, blood flow volume and pressure gradient. Automatically measure the values of maximum velocity, minimum velocity, time interval, pulsatility index and resistance index.
- Built in battery. Turn on /off the green power switch to charge /incharge the battery.

Configuration of the System

Mode	CBit 4
B mode	standard
2B mode	standard
4B mode	standard
B/M mode	standard
B/BC mode	standard
CFM mode	standard
PW mode	standard
PD mode	standard
DPD mode	standard
Instant Triplex	standard
Duplex	standard
Quadplex	standard
Trapezoidal	standard
2D Steer	standard
CW	standard
TDI	standard
Chroma B&M&PW	standard
Full Screen	standard
FHI	standard
Multiple Compound Imaging	standard
SRA (Speckle Reduction Algorithm)	standard
AIO	standard
Q-Image (intelligent image optimization)	standard
X-contrast	standard
Q-beam	standard
Q-Flow	standard
TGC	standard
LGC	standard
IMT	standard
Elastography	option
Curved Panoramic	option
Free hand 3D	option
Free Steering M mode	option
Color M mode	option
LV tracking	option

Free NT	option
Neddle Tracking	option
Niche/ Smart Volume Slice	option
Strain and Strain Ratio	option
General measurement package	standard
OB&GYN measurement package	standard
Cardiac measurement package	standard
DICOM 3.0	option
4D software package	option
Virtual HD/Depth View	option
D3C60L	standard
D7L40L	standard
D12L40L	option
D6C12L	option
D7C10L	option
D3P64L	option
D5P64L	option
V4C40L	option
D6C15L	option
D3C20L	option
Biopsy	option
Super Needle	option
Probe connector	3
USB ports	6
21.5" LCD	standard
10.1" touch screen	standard
500G hard disk	standard
DVD-R/W	standard
Foot-switch	option
WIFI Function	option
SONY UP-X898MD B&W Video Printer	option

### 3.2.4 Accessories

Transducers:

 <p>D3C60L</p> <p>Convex probe: D3C60L 2.0-6.8MHz</p>	 <p>D7L40L</p> <p>Linear probe: D7L40L 4.0-15.0 MHz</p>
 <p>D12L40L</p> <p>Linear probe: D12L40L 7.0-15.0 MHz</p>	 <p>D6C12L</p> <p>Micro convex probe: D6C12L 4.0-12.0MHz</p>
 <p>D7C10L</p> <p>Micro convex probe: D7C10L 4.0-15.0MHz</p>	 <p>D3P64L</p> <p>Phased array probe: D3P64L 1.5-5.3MHz</p>
 <p>D5P64L</p> <p>Phased array probe: D5P64L 2.0-8.0MHz</p>	 <p>V4C40L</p> <p>Volume probe: V4C40L 2.0-6.8MHz</p>
 <p>D6C15L</p> <p>Micro convex probe: D6C15L 4.0-12.0MHz</p>	 <p>D3C20L</p> <p>Micro convex probe: D3C20L 2.0-6.8MHz</p>

### 3.2.5 I/O ports

- VGA ,DVI output for external monitor
- S-VIDEO,TV output for B&W video printer or Color video printer
- Remote port for video printer
- LAN port output for PC printer, DICOM and image review station
- 6 USB 2.0 ports for flash drive
- Foot switch ports

### 3.2.6 LCD monitor

The LCD monitor support LCD lighting. Press  key on the right side of the monitor to change

the lighting level 0 to level 6.

### 3.2.7 DVD/CD-RW

The supported DVD/CD disk information and compatibility of DVD/CD-RW see the following table:

<b>DS-8ACSH</b>				
<b>Compatibility</b>		DOS 6.xx, XP / 2003 / Vista / Win7 / Win8 / Win8.1 / Linux OS		
<b>DVD</b>	<b>Write Speed</b>	DVD+R	PCAV	8X maximum
		DVD-R	PCAV	8X maximum
		DVD+R9	PCAV	6X maximum
		DVD-R9	PCAV	6X maximum
	<b>Read Speed</b>	DVD-ROM	CAV	8X maximum
	<b>ReWrite Speed</b>	DVD+RW	ZCLV	8X maximum
		DVD-RW	ZCLV	6X maximum
<b>CD</b>	<b>Write Speed</b>	CD-R	PCAV	24X maximum
	<b>Read Speed</b>	CD-ROM	CAV	24X maximum
	<b>ReWrite Speed</b>	CD-RW	ZCLV	24X maximum

## 3.3 System Positioning & Transporting

### Moving the System

When moving or transporting the system, take the precautions described below to ensure maximum safety for personnel, the system and other equipment.

### Before Moving the System

- Completely switch off the system. See Section 3.4.4 “Power Off” for more information.
- Unplug the power cord (if the system is plugged into wall outlet).
- Disconnect all cables from off-board peripheral devices (external printer, etc.) from the console.



***NOTE: To prevent damage to the power cord, DO NOT pull excessively on the cord or sharply bend the cord while wrapping it.***

- Disconnect all probes from main unit. See Section 3.5 “Probes” for more information.
- Store all probes in their original cases or wrap them in soft cloth or foam to prevent damage.
- Replace gel and other essential accessories in the appropriate storage case.
- Ensure that no loose items are left on the main unit.

## When Moving the System

Carry the system with handle, or put the system on the cart to move it. Use extra care when crossing door or elevator thresholds.



***Always use the handle to move the system. The system weighs approx. 76 kg.***

***In order to avoid possible injury or equipment damage:***

- ***Walk slowly and carefully when moving the system.***
- ***Do not let the system strike walls or doorframe.***

## Transporting the System

Use extra care when transporting the system in a vehicle. After preparing the system as described above, take the following additional precautions:

- Before transporting, place the system in its original storage case.
- Ensure that the system is firmly secured while inside the vehicle.
- Load the unit aboard the vehicle carefully and over its center of gravity.
- Keep the storage case still and upright. Secure that the system firmly with straps or as directed within the vehicle to prevent movement during transport.
- Any movement, coupled with the weight of the system, could cause it to break loose. Drive carefully to prevent damage from vibration.
- Avoid unpaved roads, excessive speeds, and erratic stops or starts.

## 3.4 Powering the System

### 3.4.1 Acclimation Time

After being transported, the unit requires one hour for each 2.5 °C increment if its temperature is below 10 °C or above 40 °C.

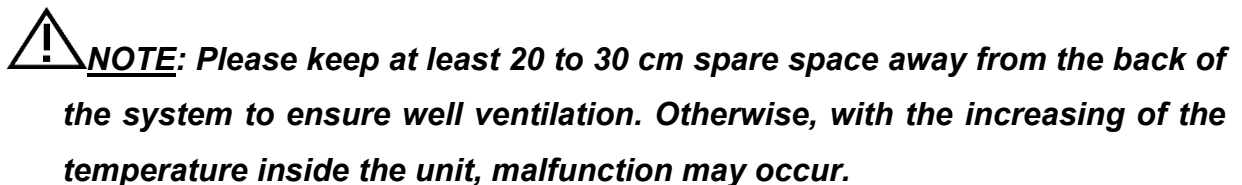

### 3.4.2 Connecting and Using the System

To connect the system to the electrical supply:

- Check the power voltage input labeling at rear panel of the system.
- Ensure that the wall outlet is the appropriate type and well grounded.
- Ensure that the system powers off.

- Unwrap the power cord, and allow sufficient slack in the cable so that the plug will not be pulled out of the wall outlet if the system is moved slightly.
- Attach the power plug to the system and secure it in place by using the retaining clamp.
- Push the power plug securely into the wall outlet.

 **NOTE:**

- ***Only use the power cord provided by Manufacturer.***
- ***Use caution to ensure that the power cord does not disconnect during system use.***
- ***If the system is accidentally unplugged, data may be lost.***

 **WARNING:**

- ***To avoid risk of fire, the system power must be supplied from a separate, properly rated outlet.***
- ***Under no circumstances should the AC power plug be altered, changed, or adapted to a configuration rated less than specified. Never use an extension cord or adapter plug.***
- ***To help assure grounding reliability, connect to a “hospital grade” or “hospital only” grounded power outlet.***

### 3.4.3 Power On

 **NOTE:**

***Turn on the green power switch (main power circuit breaker switch, see Fig. 3-1 d in Section 3.2.1 Console Overview) at the back of the system, and then press the Power button on the right of control panel to turn on the system.***

Power up Sequence:

The system is initialized and start-up status is reflected on the monitor:

- control panel flashing and then getting dark.
- system checking BIOS data.
- booting the operation system.
- loading software.
- entering examination status.

#### HINTS

The power up procedure takes about approx. 100 seconds. If a problem occurs, take

a picture and record the error information for service reference.

 **NOTE:**

- ***After power off the system, please wait for more than 3 minutes to power on again.***
- ***When the system is powered on, for safety reason, please avoid the following:***
  - ***move the system***

### 3.4.4 Power Off

To power off the system:

- Press the Power button on the right of control panel.
- When the screen shows “Turn Off”, “Standby”, and “Cancel”, press “Turn off” to shutdown the system.

 **NOTE:**

***If the system is down or has not fully shut down, press and hold the Power button located on the right of control panel for more than 4 seconds and release it, this will force the system to shut down completely.***

- ***Disconnect the probes. Clean or disinfect all probes as necessary. Store them in their original cases to avoid any damage.***
- ***To ensure the system is disconnected from the power source, disconnect power plug from the wall outlet.***

### 3.4.5 Standby

To enter standby:

- Press the power button on the right of control panel.
- Select “Standby” to enter into the standby status.

To exit standby: press the power button.

 **NOTE:**

- ***Power off the system if you will not use the system for a long period of time (including storage/transportation condition), and you should not allow the***

**system in standby status, otherwise the batteries will be out of power and permanently damaged.**

- **If you will not use the system for a long period of time, DO NOT leave the system in the standby status, you should shut down the system, disconnect power adapter, mains power, and turn off powers of all connected peripherals.**

### 3.5 Probes

 **NOTE: Only use the probes approved by Manufacturer.**

#### Selecting probes

- Choose the probe according to the different examination.
- Begin the scanning session by choosing the correct application and preset for the examination.

#### Connecting the Probe

When you connect the probes, please ensure that the probe ports are not active. Place the system in “Transducer Selection” interface by pressing PROBE-key to deactivate the probe ports.

To connect a probe:

- Place the probe’s carrying case on a stable surface and open the case.
- Carefully remove the probe and unwrap the probe cord.
- DO NOT allow head of the probe hang freely. Impact to head of the probe could result in irreparable damage.

 **NOTE: Inspect the probe before and after each use for damage or degradation to the housing, strain relief, lens, seal and connector. DO NOT use a probe that appears damaged until its functional and safe performance is verified. A thorough inspection should be performed during the cleaning process.**

- Align the connector with the probe port and carefully push into place with the cable facing the back of the system.

---

Turn the probe connector locking lever to “lock” status.

---

- Carefully position the probe cord so it is free to move and is not resting on the floor.
- When the probe is connected, the system will be automatically recognized.

 **CAUTION:**

- **Fault conditions can result in electric shock hazard. DO NOT touch the surface of probe connector that is exposed when the probe is removed. DO NOT touch the patient when connecting or disconnecting a probe.**
- **Take precautions with probe cables. DO NOT bend the cable acutely.**

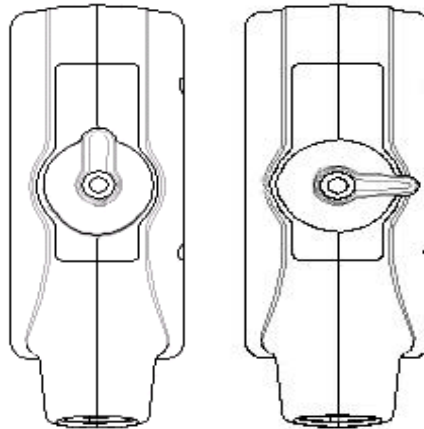

Fig.3-2 a Probe connector “Unlock” status

Fig.3-2 b Probe connector “Lock” status

## Deactivating the Probe

When deactivating the probe, the probe is automatically placed in a standby mode.

To deactivate a probe:

- Ensure the system is in “Transducer Selection” interface. If necessary, press the PROBE-key to return.
- Gently wipe off the excess gel from the probe surface.
- Carefully slide the probe toward the probe holder, and place the probe gently in the probe holder.

## Disconnecting the Probe

Probes can be disconnected when the system is “Transducer Selection” interface.

To disconnect a probe:

- Turn the connector locking lever to an “Unlock” position.
- Pull the probe and connector straight out of the probe port.
- Carefully slide the probe and connector away from the probe port.
- Ensure that the head of the probe is clean before placing the probe in its storage box.

## Transporting the Probe

When transporting a probe a long distance, store it in its original carrying case.

## Storing the Probe

It is recommended that all probes should be stored in the original carrying case.

- Place the probe connector into the carrying case.
- Carefully wind the cable into the carrying case.
- Carefully place the probe head into the carrying case. DO NOT use excessive force or impact on the probe head.

## 3.6 Optional installation

### 3.6.1 Connect the printer

- 1) It needs three cables: Remote cable, Video signal cable, Power cord. See picture in Fig.3-3.
- 2) Connect the remote cable to remote port on the back panel of ultrasound system. See picture in Fig.3-3.
- 3) Connect the video signal cable to the Video Out port on the back panel of the ultrasound system. See picture in Fig.3-3.
- 4) Connect the Power cord to the Power output of auxiliary mains on the back panel of the ultrasound system. See picture in Fig.3-3.

 **NOTE:** *If you don't connect remote cable, you still can do the printing by pressing the key on printer.*

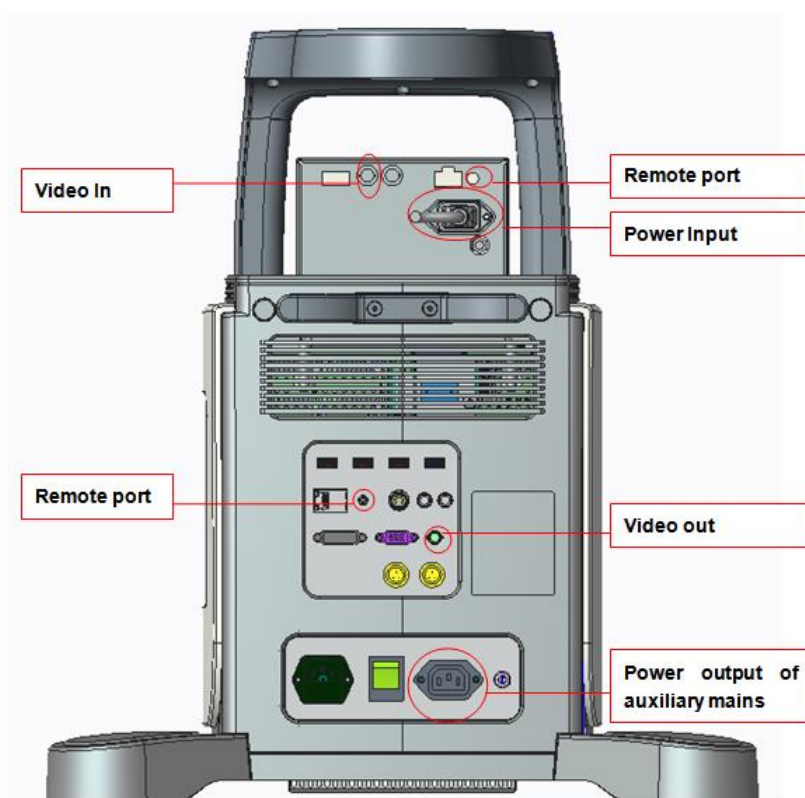

# CHISON



**CHISON Medical Technologies Co., Ltd.**

---

No.3 Changjiang South Road, Xinwu District, Wuxi, 214028 Jiangsu, P.R. China